

# Thời Gian

ADVERTISING RATES  
MEDIA INFORMATION

2009

# Thời Gian

## THOI GIAN AT A GLANCE

- Thoi Gian is the only proven, focussed and targeted market entry platform to Vietnam for the international watch trade.
- Thoi Gian offers a unique opportunity to make a statement amongst competitors and establish a branding platform in a rapidly expanding market.
- Thoi Gian showcases your company's background, its unique style and the products; all in the very same glamorous and up-market format Solitaire magazine is reputed for.
- Thoi Gian is compiled and edited once a year in Singapore by Solitaire Media, then translated into Vietnamese, printed in Vietnam and mass-circulated throughout Vietnam's major population centres.
- Thoi Gian is sold over a six-month period at all major news vendors in Vietnam.
- Thoi Gian is subsequently given away in substantial quantities at premier airline lounges, five-star hotels, golf clubs, marina clubs, spas and beauty salons throughout Vietnam.
- Thoi Gian has established itself as an object of desire for an exploding number of Vietnamese hungry for a better lifestyle.
- Thoi Gian - Vietnam's only one-stop keepsake guide to the world's leading watch brands. Don't miss it.

## TARGET AUDIENCE

- Affluent young professionals, business owners and senior management
- Expatriates in the country
- Premier class business travellers
- Members of premier private clubs and loyalty programs
- Luxury shoppers and tourists
- Watch collectors and watch enthusiasts

## THOI GIAN CONCEPT AND CIRCULATION

- Yearbook-style reference book, featuring 100 world leading famous brands
- Brands are listed alphabetically from A-Z
- Brand listing are interspersed with educational and other related editorial content, covering watch-making history, technical terms, trend pieces etc
- No company logos in editorial text, only possible via advertising
- High-end finishing, A4 size, glossy art paper, covers laminated
- Vietnamese language throughout, except names of individual brands in chapter headlines
- Distributed in Hanoi, Ho Chi Minh (Saigon), Danang, Can Tho, Hai Phong
- Circulation of 25,000; printed in Vietnam
- Approximately 70% given away free over a six-month period at premier circulation points, such as spas, beauty salons, upmarket coffee shops, selected nightclub lounges, country clubs, golf clubs, hotels, airline lounges etc
- Approximately 30% sold on news-stands, news vendors etc, over a six-month period

## ADVERTISING RATES (ALL RATES IN US DOLLARS)

ADVERTISING	RATE PER INSERTION
Front Cover Picture (editorial-style image only)	USD 19,000
Outside Back Cover	USD 12,000
Inside Front Cover Spread	USD 11,000
Prime Double Page Spread	USD 7,900
Inside Back Cover Spread	USD 4,900
Prime Page	USD 4,500
Run of Page	USD 2,900

## BRAND LISTING

BRAND LISTING	RATE PER INSERTION
Half Page	Free-Of-Charge
Upgrade to one page	USD 1,500
Upgrade to two pages	USD 2,500
Upgrade to four pages	USD 4,800

## BRAND LISTING COVERAGE SPECIFICATIONS

### HALF PAGE (FREE-OF-CHARGE)

- Brand name as headline
- Basic write-up by publication (approximately 150 words)
- One current product image

### ONE PAGE (USD 1,500)

- Brand name as headline
- Short write-up by publication (approximately 300 words)
- Three current product images
- Website address

### TWO PAGES (USD 2,500)

- Brand name as headline
- Medium write-up by publication (approximately 400-450 words)
- Six current product images
- One model shot
- Website address
- Email contact

### FOUR PAGES (USD 4,800)

- Brand name as headline
- Full-length write-up by publication (approximately 600-650 words)
- Company timeline
- Fifteen product images (current and historical)
- Five model and/or factory shots
- Full contact details (website, email, address, phone, fax)
- Detailed listing of all distributors and/or boutiques in Asia

One page brand listing



Two pages brand listing



Four pages brand listing



### Please note:

- The advertising rates are on a per insertion basis only.
- Rates are exclusive of 10% VAT. VAT is applicable only to advertisers from Vietnam.

## ADDITIONAL CHARGES

- Rates quoted are for presswork only. Not included are artwork modifications, colour separations, stripping or other production work.
- If the publisher is required to handle this work, the advertiser will be charged at cost. Approximate charges for this additional work are:
  - Layout modifications on electronic files: USD 50 per change
  - Mechanical artwork: between USD 100 - 300 per advertisement, depending on design
  - Colour separation with mechanical proof (if required by advertiser): between USD 80 and 120 per set, depending on size
- Notice of cancellation must be given at least 6 weeks before material deadline. A levy of 30% of contracted rate will be imposed per cancellation. If cancellation is made later than 6 weeks before material deadline, the full contract price is chargeable.

# Thời Gian

## BRAND PROFILE AND ADVERTISING DEADLINES

BRAND LISTING	
Placement Deadline	09 June 2009
Material Deadline	23 June 2009
Publication Date	September 2009

ADVERTISING	
Placement Deadline	03 August 2009
Material Deadline	17 August 2009
Publication Date	September 2009

### Please Note:

Material deadline is for printer-ready material (electronic files or films). If material is to be produced by the publisher, all text and images must arrive at publisher's office latest by booking deadline. The publisher reserves the right to refuse all ad material deemed unsuitable for the publication.

### Standard Ad Sizes

- Maximum print area in mm, width x height. Please refer to chart below:

Double Page Spread Ads

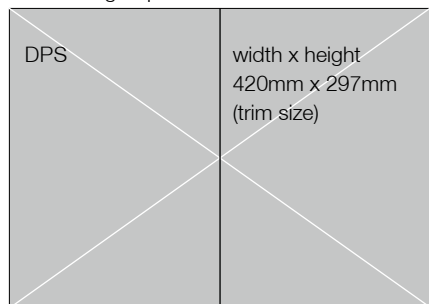

Bleed Ads

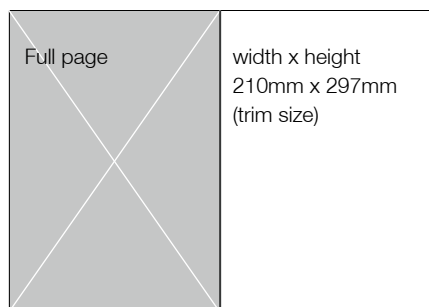

- Bleed ads are allowed at no extra cost to the advertiser, but for full-page and double-page spread ads only.
- An extra 3mm must be allowed for cross-gutter ads. Publisher reserves the right to trim up to 5mm off each edge of the trimmed page dimensions. Type matter and illustrative material must therefore be kept within these tolerances.

### Technical Specifications

- Printing: Sheet-fed offset at 175 lines per inch
- Pre-Press: Colour Separations with proofs and Computer-to-Plate (CTP) process
- Finishing: Perfect binding, covers laminated
- Paper: Cover: 350gsm glossy art, Content: 120gsm glossy art
- Trim Size: 210mm width x 297mm height
- Type Size: 180mm width x 260mm height
- Film Size: 220mm width x 310mm height (full page)

### Material Supply

- Electronic
  - If material is supplied in electronic form, publisher requires PDF or TIFF format with crop marks all around according to our trim size.
  - Electronic material supplied in zip or CD should preferably be in PC format. These must have two colour proofs for checking purposes. Publisher will match colours on best-effort basis.
  - If you are sending electronic material via email, its file size must be less than 8MB. Please email it to: [traffic@solitairemedia.com](mailto:traffic@solitairemedia.com)
- Non-Electronic
  - If advertising material is supplied in film form, publisher requires unretouched positives, right-reading, emulsion side down. Films must show registration marks, corner marks and colour indicators on each film, corresponding to the trim size of the publication.
  - At least two colour proofs plus one set of progressives must accompany films. Without complete colour proofs, the publisher declines responsibility for colour accuracy. Publisher reserves the right to match spot or second colours with process colours on a best-effort basis.

### Please Note:

All electronic and non-electronic reproduction material and proofs should be sent by air-courier to:

#### EDIPRESSE SOLITAIRE MEDIA PTE LTD

101 Cecil Street #10-12

Tong Eng Building, Singapore 069533

Tel: +65 6835 9030 Fax: +65 6835 9520

### Contact Us

#### Singapore

#### EDIPRESSE SOLITAIRE MEDIA PTE LTD

101 Cecil Street #10-12

Tong Eng Building, Singapore 069533

Tel: +65 6835 9030 Fax: +65 6835 9520

Email: [thoigian@solitairemedia.com](mailto:thoigian@solitairemedia.com)

Website: [www.solitairemedia.com](http://www.solitairemedia.com)

#### Vietnam

#### ORIENTAL LTD (DONG PHUONG LTD)

307/27 Nguyen Van Troi, Tan Binh District

Ho Chi Minh City (Saigon), Vietnam

Tel: +84 8 844 1612 Fax: +84 8 846 2296

Email: [thoigian@oriental-ltd.com](mailto:thoigian@oriental-ltd.com)

Website: [www.thoi-gian.com](http://www.thoi-gian.com)