

solitaire

THE ART OF **FINE JEWELLERY**

ADVERTISING RATES & MEDIA INFORMATION



solitaire

Solitaire is a regional bi-monthly jewellery and trend consumer title, appreciated and collected by Asia Pacific's jewellery and watch connoisseurs. Featuring insider reporting supplied by a network of specialist correspondents in over twenty countries, Solitaire showcases the latest jewellery fashion and watch trends in an easy-to-digest format and a stylish presentation even other magazines talk about.

We reach the affluent clients you need.

OUR READERS

WHO READS SOLITAIRE?

- Asian Professionals and Affluent Consumers
 - Business Owners and Senior Management
 - Financially independent personalities
 - 80/20 female-to-male ratio
 - Fashion, trend and status-oriented individuals
 - Within the upper 20% of the income pyramid
- Expatriates in Asia Pacific
 - Senior Management and Professionals
 - 80/20 female-to-male ratio
 - Substantial disposable income
- Premier class business travellers in Asia Pacific
- Members of premier private clubs and loyalty programmes in Asia Pacific
- International luxury shoppers and tourists to or through Asia Pacific metropolitan areas
- Private customers of regional and international jewellery and watch private showcases, social gatherings and other exclusive events
- Jewellery and watch collectors and professionals throughout Asia Pacific

OUR AUDIENCE & REACH

WHERE ARE OUR READERS?

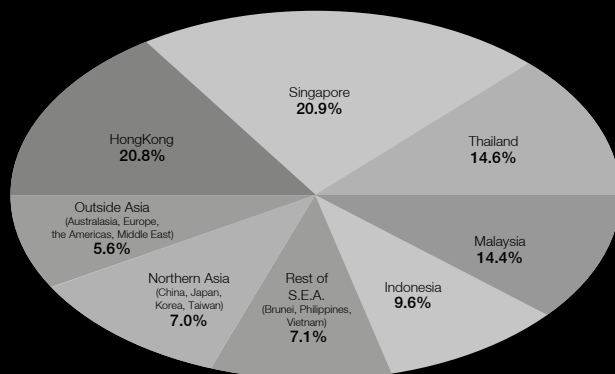

HOW ARE WE DISTRIBUTED?

Circulation by category

- 49.9% Paid Circulation
- 45.9% Premier Circulation
- 4.2% Events Circulation



- Paid Circulation
 - Bookshops and news-stands
 - Worldwide by paid subscription
- Premier Circulation
 - Uplifted onto first-class and business-class compartments of selected premier airlines and national carriers flying Asia Pacific routes
 - First-class and business-class lounges at selected premier Asia Pacific airports
 - Suites and executive club rooms of exclusive Asia Pacific hotels and resorts
 - Members of selected social and loyalty clubs throughout Asia Pacific
 - Privileged clients of selected private banking and premier credit card organizations
- Event Circulation
 - Selected international and regional jewellery and watch events, high profile social gatherings, art exhibitions, etc.

HOW SOLITAIRE CAN HELP YOU

- Solitaire is the leading and only established jewellery and watch consumer magazine in the Asia Pacific region
- Solitaire is the proven choice for luxury branding and also significantly increasing sales. Our advertisers prove their satisfaction in working with Solitaire by working with us continuously over the years
- Our comprehensive circulation network connects you instantly to your potential customers in Asia Pacific



ADVERTISING RATES (ALL RATES IN HKD)

FULL PAGE POSITION	RATE PER INSERTION
Regular Position (second half of magazine)	HKD 40,800
Preferred Position (first half of magazine)	HKD 64,800
Prime Position (first 25% of magazine, guaranteed right hand, facing editorial pages)	HKD 76,800

DOUBLE PAGE SPREAD POSITION	RATE PER INSERTION
Preferred Double Page Spread Position (first half of magazine)	HKD 112,800
Prime Double Page Spread Position (first 25% of magazine)	HKD 130,800

PREMIUM COVER POSITION	RATE PER INSERTION
Outside Gate Fold Spread (Z-Fold Double Page Only)	HKD 146,880
Inside Front Cover Spread (Double Page Spread Only)	HKD 128,280
Outside Back Cover	HKD 142,800
Inside Back Cover	HKD 70,800

MARKET PLACE POSITION	RATE PER INSERTION
Half Page Position (Horizontal, second half of magazine)	HKD 20,800

SPECIAL BUY	RATE
Available as Bound & Loose Inserts, Gate Folds, Belly Bands, Art Card, etc.	Please contact business@solitairemedia.com

DISCOUNTS & INCENTIVES

FREQUENCY DISCOUNTS

- 5% Discount with 3x Insertions
- 15% Discount with 6x Insertions

PREPAYMENT INCENTIVES

- Additional 3% discount for 3 issues prepayment
- Additional 8% discount for 6 issues prepayment

ADDITIONAL CHARGES

- Rates quoted are for presswork only. Not included are artwork modifications, colour separations, stripping or other production work.
- If the publisher is required to handle this work, the advertiser will be charged at cost. Approximate charges for this additional work are:
 - layout modifications on electronic files: HKD 544 per hour
 - Mechanical artwork: between HKD 3,020 - HKD 4,833 per advertisement, depending on design
 - Colour separations with mechanical proof (if required by advertiser): between HKD 785 – HKD 1,208 per set, depending on size
- Notice of cancellation must be given at least 6 weeks before material deadline. A levy of 30% of contracted rate will be imposed per cancellation.
- If cancellation is made later than 6 weeks before material deadline, the full contract price is chargeable.

PUBLISHER

EDIPRESSE SINGAPORE PTE LTD
 211 Henderson Road #07-04
 Singapore 159552
 T: +65 6323 1606
 F: +65 6323 1692
 W: www.solitairemedia.com

Please direct enquiries to the following email addresses:

Advertising jesline.lim@edipresse.com.sg

Editorial solitairemedia@edipresse.com.sg

ADVERTISEMENT SCHEDULE & AD SIZE SPECIFICATIONS

ISSUE	BOOKING DEADLINE	MATERIAL DEADLINE	PUBLICATION
February / March	25 December	05 January	01 February
April / May	25 February	05 March	01 April
June / July	25 April	05 May	01 June
August / September	25 June	05 July	01 August
October / November	25 August	05 September	01 October
December / January	25 October	05 November	01 December

Please Note:

Material deadline is for printer-ready material (electronic files or films). If material is to be produced by the publisher, all text and images must arrive at publisher's office latest by booking deadline. The publisher reserves the right to refuse all ad material deemed unsuitable for the publication, in particular advertisements showing retail prices, religious symbols and nudity.

STANDARD AD SIZES

- Maximum print area in mm, width x height. Please refer to chart below:

Double Page Spread Ads

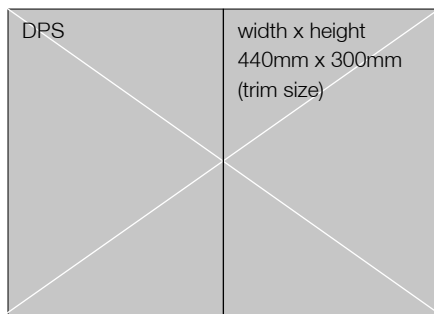

Bleed Ads

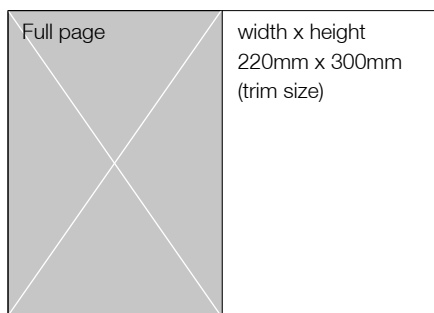

Non-Bleed Ads

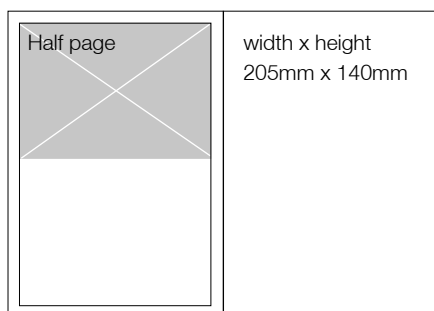

- Bleed ads are allowed at no extra cost to the advertiser, but for full-page and double-page spread ads only.
- An extra 3mm must be allowed for cross-gutter ads. Publisher reserves the right to trim up to 5mm off each edge of the trimmed page dimensions. Type matter and illustrative material must therefore be kept within these tolerances.

TECHNICAL SPECIFICATIONS

- Printing: Sheet-fed offset at 175 lines per inch
- Pre-Press: Colour Separations with proofs and Computer-to-Plate (CTP) process
- Finishing: Perfect binding, covers laminated
- Paper: Cover: 260gsm glossy art,
- Content: 115gsm glossy art
- Trim Size: 220mm width x 300mm height
- Type Size: 185mm width x 270mm height
- Film Size: 230mm width x 310mm height (full page)

MATERIAL SUPPLY

- Electronic
 - If material is supplied in electronic form, publisher requires PDF or TIFF format with crop marks all around according to our trim size.
 - Electronic material supplied in zip or CD should preferably be in PC format. These must have two colour proofs for checking purposes. Publisher will match colours on best-effort basis.
 - If you are sending electronic material via email, its file size must be less than 8MB. Please email it to: traffic@solitairemedia.com
- Non-Electronic
 - If advertising material is supplied in film form, publisher requires un-retouched positives, right-reading, emulsion side down. Films must show registration marks, corner marks and colour indicators on each film, corresponding to the trim size of the publication.
 - At least two colour proofs plus one set of progressives must accompany films. Without complete colour proofs, the publisher declines responsibility for colour accuracy. Publisher reserves the right to match spot or second colours with process colours on a best-effort basis.

Please Note:

All electronic and non-electronic reproduction material and proofs should be sent by air-courier to:

EDIPRESSE Singapore Pte Ltd
 211 Henderson Road #07-04, Singapore 159552
 Tel: +65 6323 1606 Fax: +65 6323 1692